

REVISIONS				
REV	DESCRIPTION	E.C.N.	DATE	BY/APP'D
1	RELEASE TO DOCUMENT CONTROL	#	MM/DD/YY	NAME

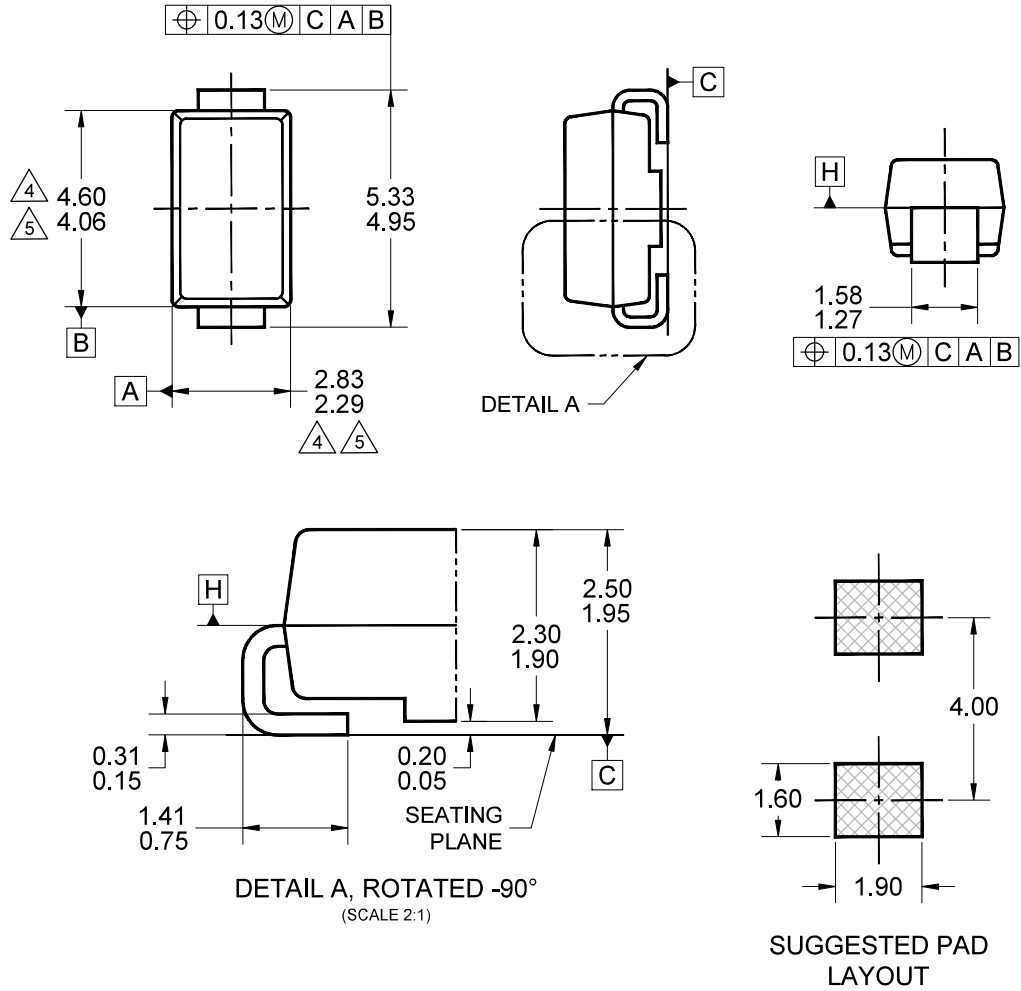

NOTES: UNLESS OTHERWISE SPECIFIED

1. ALL DIMENSIONS ARE IN MILLIMETERS.
2. DIMENSIONING AND TOLERANCING PER ASME Y14.5M-1994.
3. PACKAGE OUTLINE REFERENCE: JEDEC DO-214, VARIATION AC, ISSUE D.
4. MOLDED PLASTIC BODY DIMENSIONS DO NOT INCLUDE MOLD FLASH.
5. MOLDED PLASTIC BODY LATERAL DIMENSIONS TO BE DETERMINED AT DATUM PLANE H.
6. DWG NO. REF: HQ2SD07-DO214SMC-034 REV A.

REVISIONS				
REV	DESCRIPTION	E.C.N.	DATE	BY/APP'D
1	RELEASE TO DOCUMENT CONTROL	#	MM/DD/YY	NAME

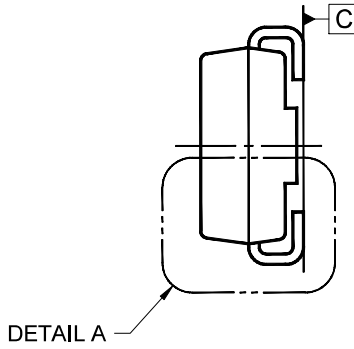
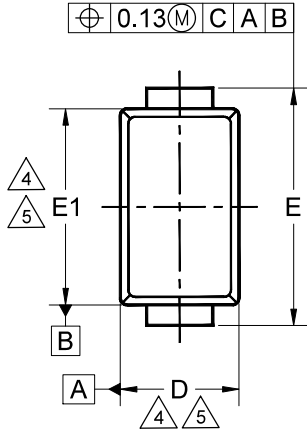

DIM	Unit (mm)	
	Min	Max
A	1.95	2.50
A1	1.90	2.30
A2	0.05	0.20
b	1.27	1.58
c	0.15	0.31
D	2.29	2.83
E	4.95	5.33
E1	4.06	4.60
L	0.75	1.41

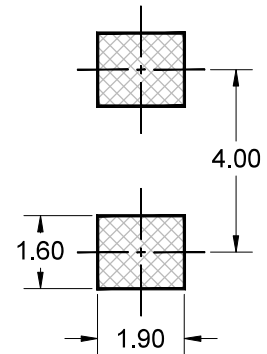
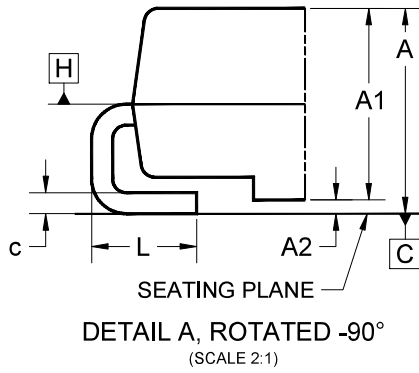
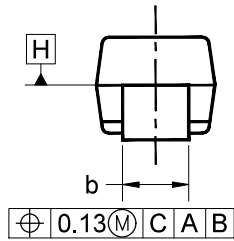

SUGGESTED PAD LAYOUT

NOTES: UNLESS OTHERWISE SPECIFIED

1. ALL DIMENSIONS ARE IN MILLIMETERS.
2. DIMENSIONING AND TOLERANCING PER ASME Y14.5M-1994.
3. PACKAGE OUTLINE REFERENCE: JEDEC DO-214, VARIATION AC, ISSUE D.
4. DIMENSIONS D AND E1 DO NOT INCLUDE MOLD FLASH.
5. DIMENSIONS D AND E1 TO BE DETERMINED AT DATUM PLANE H.
6. DWG NO. REF: HQ2SD07-DO214SMC-034 REV A.

CLEARANCE REVIEW OF SCALED UNIT OVERLAY ON TOP OF PAD LAYOUT, 2LD DO-214AC (SMA)

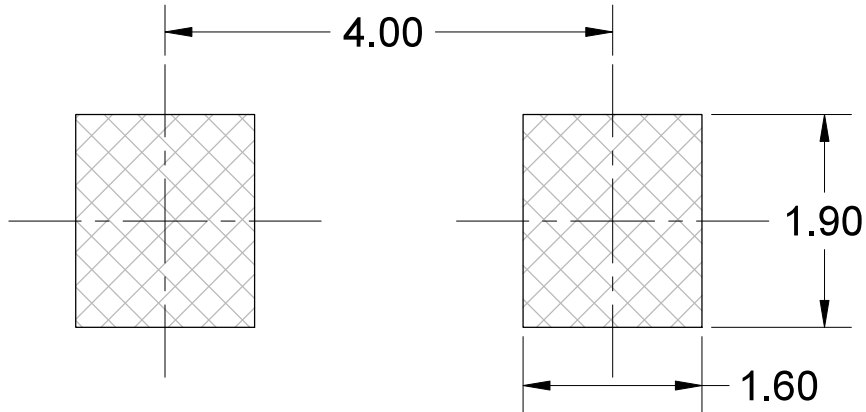

PAD LAYOUT

